



Milan Series Gas Fireplace

Milan 60

Milan 72



Installation Operation and Maintenance Manual

Check local codes and read all instructions prior to installation.

Warning:

Improper installation, adjustment, alteration, service or maintenance can cause injury or property damage. Refer to this manual. For assistance or additional information consult a qualified installer, service agency or the gas supplier.

Safety Notice:

Glass doors on gas fireplaces are extremely hot while the fireplace is on and remain hot even after the fireplace has been turned off. Safety screens are available and can reduce the risks of severe burns. Please keep children away from the fireplace at all times.

For Your Safety:

Do not store or use gasoline or other flammable vapors and liquids in the vicinity of this or any other appliance.

Warning:

What to do if you smell gas

- *Do not try to light any appliance.*
- *Do not touch any electrical switch; do not use any phone in your building.*
- *Immediately call your gas supplier from a neighbor's phone. Follow the gas supplier's instructions.*
- *If you cannot reach your gas supplier, call the fire department.*



- *Installer: Leave this manual with the appliance.*
- *Consumer: Leave this manual for future reference.*

 **Warning:**
 Read this manual before installing, operating or troubleshooting this appliance.
 Please retain this owner's manual for future reference.

Congratulations!

Thank you for selecting a European Home gas fireplace, an elegant and well designed gas fireplace built with you in mind. The European Home gas fireplace you have selected is designed to provide the utmost in safety, reliability, and engineering standards.

As the owner of this new fireplace, you'll want to read and carefully follow all the instructions contained in this Installation, Operations and Maintenance manual. Pay special attention to all cautions, warnings, and notices.

This owner's manual should be retained for future reference. We suggest that you keep it with all your other important documents and product manuals.

The information contained in this owner's manual, unless noted otherwise, applies to all models, and gas control systems.

Your new European Home gas fireplace will give you years of durable, reliable use. Welcome to the European Home family of gas fireplace products.

Safety Alert Key:

- **DANGER!** Indicates a hazardous situation which, if not avoided will result in death or serious injury.
- **WARNING!** Indicates a hazardous situation which, if not avoided could result in death or serious injury.
- **CAUTION!** Indicates a hazardous situation which, if not avoided, could result in minor or moderate injury.
- **NOTICE:** Used to address practices not related to personal injury.
- **Important:** Used to address practices not related to personal injury.

Table Of Contents

<p>Congratulations</p> <p>Safety Alert Key</p> <p>Introduction 3</p> <p style="padding-left: 20px;">Warranty and Installation 3</p> <p>Installation</p> <p style="padding-left: 20px;">Installing the Fireplace 4-5</p> <p style="padding-left: 40px;">Dimensions 4</p> <p style="padding-left: 40px;">Clearances 4</p> <p style="padding-left: 20px;">Vent Installation 5</p> <p style="padding-left: 20px;">Vent Terminations 5</p> <p style="padding-left: 40px;">Exterior Power Vent Installation 5</p> <p style="padding-left: 40px;">Exterior Power Vent Wire Routing 5</p> <p style="padding-left: 20px;">Power Vent Installation 6 - 12</p> <p style="padding-left: 40px;">EDVRR Roof Mounted Power Vent Install 6 - 9</p> <p style="padding-left: 40px;">EDVRW Wall Mounted Power Vent Install 9 - 12</p> <p style="padding-left: 20px;">Converting To Top/Rear Vent 12</p> <p style="padding-left: 20px;">Converting the Pressure Sensing Tube 12</p> <p style="padding-left: 20px;">Testing the System Prior to Framing 12 - 13</p> <p style="padding-left: 20px;">Installing the Gas Line 13</p> <p style="padding-left: 20px;">Framing 13 - 16</p>	<p style="padding-left: 20px;">Finishing Around the Fireplace 16</p> <p style="padding-left: 20px;">Fireplace Facing 16</p> <p style="padding-left: 20px;">Mantels and Surrounds 16</p> <p style="padding-left: 20px;">Installation of Electrical Supply 17</p> <p style="padding-left: 20px;">Installing the Remote Switch 17</p> <p style="padding-left: 20px;">Electrical Schematic 18</p> <p>Operation 19</p> <p style="padding-left: 20px;">Start Up Sequence 19</p> <p>Maintenance 20 - 23</p> <p style="padding-left: 20px;">Removing and Installing the Door 20</p> <p style="padding-left: 20px;">Installing the Glass Beads and Optional Fire Media 20</p> <p style="padding-left: 20px;">General Observations 21</p> <p style="padding-left: 20px;">Cleaning 21</p> <p style="padding-left: 20px;">Troubleshooting 22</p> <p style="padding-left: 20px;">Gas Control Valve 22</p> <p>Warranty 23</p> <p>Appendix A Termination Locations 24</p> <p>Appendix B (State of Massachusetts) 25</p>
---	---

Introduction

Thank you for choosing a European Home Gas Fireplace.

The **Milan Series** Fireplaces are linear burner power vented fireplaces. The **Milan 60** and **Milan 72** use the European Home 5"/10" Power Vent System. This venting system is ideal for very long or difficult venting runs.

- The **Milan 60** is rated for Natural Gas at 80,000 BTU/Hr. (23.2 Kilowatts) input, and Propane at 65,000 BTU/Hr. (18.9 Kilowatts). Use 5"/10" dia. European Home Certified Coaxial Vent.
- The **Milan 72** is rated for Natural Gas at 100,000 BTU/Hr. (29.0 Kilowatts) input, and Propane at 80,000 BTU/Hr. (23.2 Kilowatts). Use 5"/10" dia. European Home Certified Coaxial Vent.

This manual covers installation, operation and maintenance. Lighting, operation and care of this fireplace can be easily performed by the homeowner. However, all installation and service work should be performed by a qualified or licensed installer, plumber, or gasfitter who is qualified or licensed by the state, province, region, or governing body in which the appliance is being installed.

This manual covers all models and unless otherwise specified, the designation **Milan Series** refers to all models. Sections which are specific to a particular model are marked with a  symbol plus the appropriate model number.

Warranty and Installation Information:

The European Home warranty will be voided by, and European Home disclaims any responsibility for, the following actions:

- Modification of the fireplace and/or components including power vent assembly or glass panels.
- Use of any component part not manufactured or approved by European Home in combination with this European Home fireplace system.
- Installation other than as instructed in this manual.

Consult your local Gas Inspection Branch on installation requirements for factory-built gas fireplaces. Installation and repairs should be done by a qualified contractor.

Installations in Canada must conform to the current **CAN/CGA B-149.1** and **.2** Gas Installation Code and local regulations.

Installations in the USA must conform to local codes, or in the absence of local codes to the National Fuel Gas Code, **ANSI Z223.1-1988**.

See **Appendix B** for installation within the **State of Massachusetts**.



CAUTION!

Due to its high operating temperatures, the appliance should be located out of traffic & away from furniture and draperies.

- Children and adults should be alerted to the hazards of the high surface temperature, which could cause burns or clothing ignition.
- Young children should be carefully supervised when they are in the same room as the appliance.
- Clothing or other flammable materials should not be placed on or near the appliance.

Installing The Fireplace

Introduction to the Milan Series Fireplace:

The complete system will require a fireplace a power vent module a electrical control panel as well as the appropriate vent system to connect the fireplace to the power vent module placed in a vertical or horizontal location. The Milan Series fireplace is not a heat efficient fireplace and should not be used to heat your home. This product is a decorative fire feature and should only be used to enhance the ambiance of the room.

Basic Concept of the Milan Series Fireplace System:

The control compartment of this fireplace is located in the bottom of the fireplace right below the burner system. All models will be supplied with a Honeywell Smart Valve gas control and will not have a variable flame control. There are two air switches that are controlling the gas control system, and are located in the bottom of this fireplace. These gas valves and pressure switches communicate with the electrical control panel via a six conductor cable supplied with the fireplace. To operate the fireplace, European Home has supplied and installed twenty feet of low voltage wire to this electrical control panel. Connect the two wire harness to a standard single pole on/off switch at a location of your choice. You may also extend these wires to any length, as long as you select a wire of equal quality.

The Milan Series Fireplace Installation Location:

Your **Milan** Fireplace may be installed in any location that maintains proper clearances to air conditioning ducts, electrical wiring and plumbing. Safety, as well as efficiency of operation, must be considered when selecting the fireplace location. Try to select a location that does not interfere with room traffic, has adequate ventilation, and offers an accessible pathway for vent installation. Refer to **Vent Installation Section** for more information.

Installation



WARNING

The Milan Series unit is a power vented fireplace system. Under no circumstances can this model be installed without a power vent module. For regular horizontal vent installation use model EPVRW with the rough-in kit model EPVRWF. For regular vertical installation use model EPVRR with a rough-in kit model EPVRRF.

Should your vent run be in excess of our vent parameters, a more powerful power vent module is available. For horizontal vent runs select model EPVRW2. For vertical vent runs select model EPVRR2. These power vent modules will utilize the same rough-in kit as well as the same electrical panel.

Dimensions

The fireplace dimensions are shown below and on the following page:

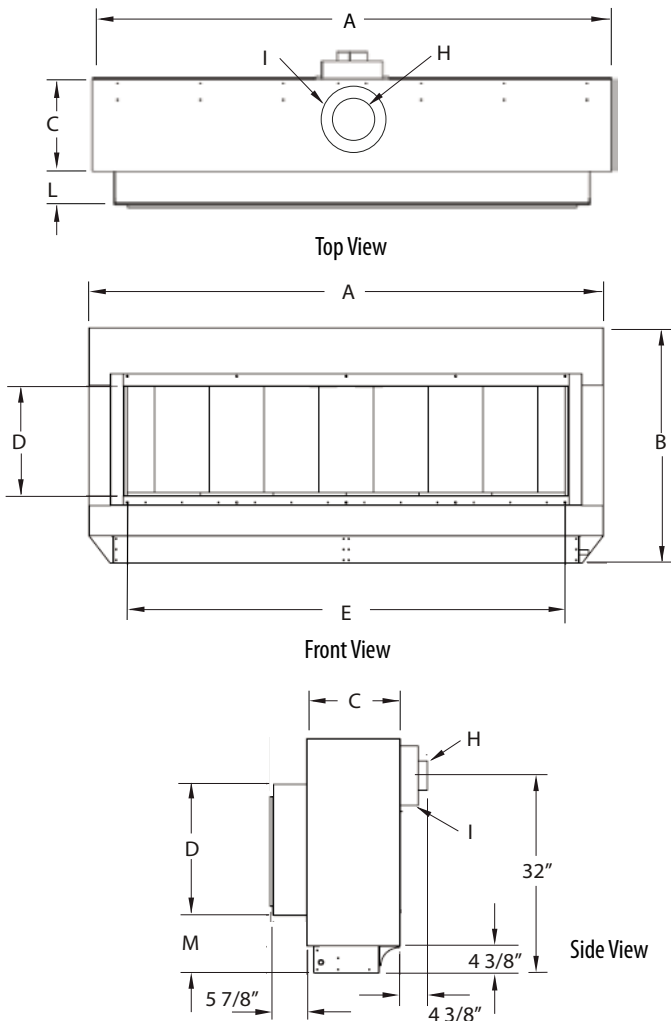

Milan Series Fireplace Dimensions														
	A	B	C	D	E	F	G	H	I	J	K	L	M	N
60	72"	38"	15 1/2"	18	60	N/A	N/A	5	10	12 1/2"	—	5 1/2"	9 3/4"	—
72	84"	38"	15 1/2"	18	72	N/A	N/A	5	10	12 1/2"	—	5 1/2"	9 3/4"	—

Figure 1. Milan Series Fireplace Dimensions.

WARNING!

When this appliance is installed directly on any combustible materials other than wood flooring, (carpet, vinyl flooring, etc.) it must be installed on a equivalent wood or metal panel. This material must extend the full width and depth of the appliance shown.

Clearances

To ensure the Milan Series Fireplace operates safely all models must maintain the following clearances.

Clearance	Model	
	60	72
Top (Rear Vent)	10"	10"
Top (Top Vent)	10"	10"
Back	2"	2"
Sides	3"	3"
Floor	0"	0"
Mantle	6"	6"

Unprotected combustible walls which are perpendicular to the fireplace opening, must not be closer to the fireplace than the described in Figure 16.

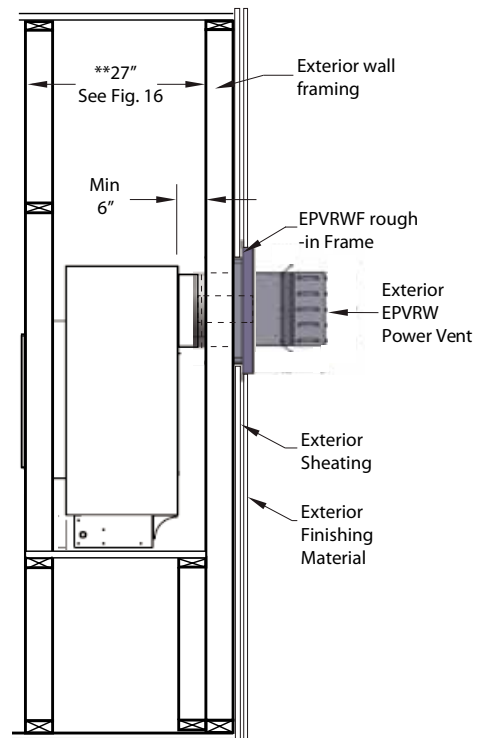

Figure 1a. Milan Series Rear clearance dimensions.



Installation

Vent Installation

Before installing the rough-in kit on your roof or wall install the electrical cord model EPVH-10 to model EPVH-100 and connect it to the electrical control panel that was supplied with the fireplace. Do not attach the electrical wire to the exterior of the vent. The vent will get hot and may damage the wire.

Install the power vent rough-in kit in its predetermined location and install the vent system from the rough-in kit to the fireplace. When the vent is near the fireplace you should have a male end aiming towards the fireplace connection which also has a male connection.

Vent Terminations

Selecting a Termination Location

Before installing the termination or venting, check to ensure the planned termination location is acceptable and meets basic requirements shown in *Figure 3*, and *Appendix A (Termination Locations)*.

Installing the Terminations with Frame

1. Frame the termination opening for fireplace models, **Milan 60** and **Milan 72**, pages 6 to 9. (*vertical and horizontal vent runs*)
2. Fasten the termination and its frame in place using a minimum of 4 screws, See *Figure 2* below.

Vertical EPVRR (Top Vent) Venting & Terminations, pages 5-7

Horizontal EPVRR (Wall Vent) Venting & Terminations, pages 7-9.

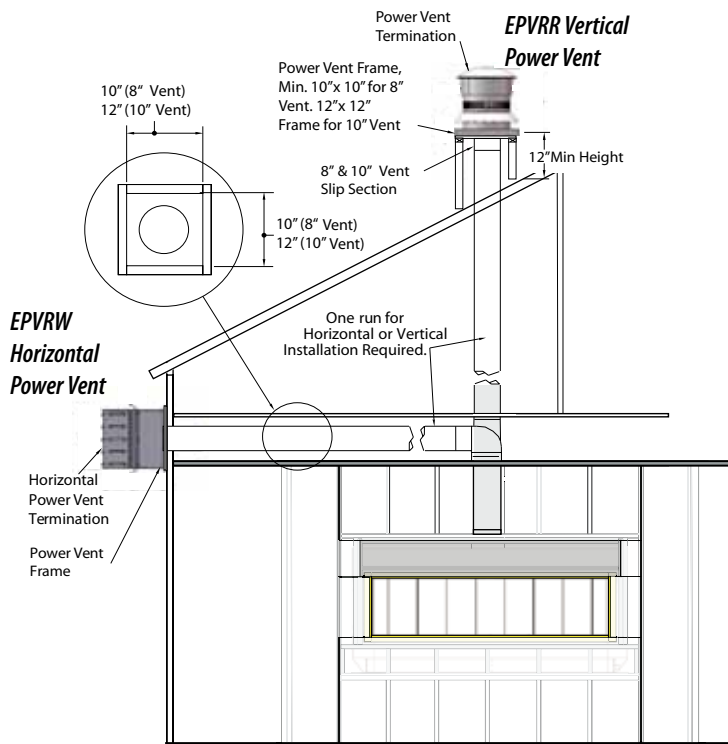

Figure 2. Typical Milan Series Vertical (Top Vent) Power Vent Coaxial configuration.



Cautions:

- Vent terminations can be very hot. The termination is to be installed higher than 7 feet above a public walkway.
- Do not obstruct, or attempt to conceal, the vent termination. These actions will affect the operation of the fireplace and may be hazardous.
- In heavy snow areas, take extra care to prevent snow buildup from obstructing the vent termination.

Locating the Power Vent Control Box

Locate the Power Vent Control Box in an accessible location. The location should be where maintenance, adjustments and service may be made easily.

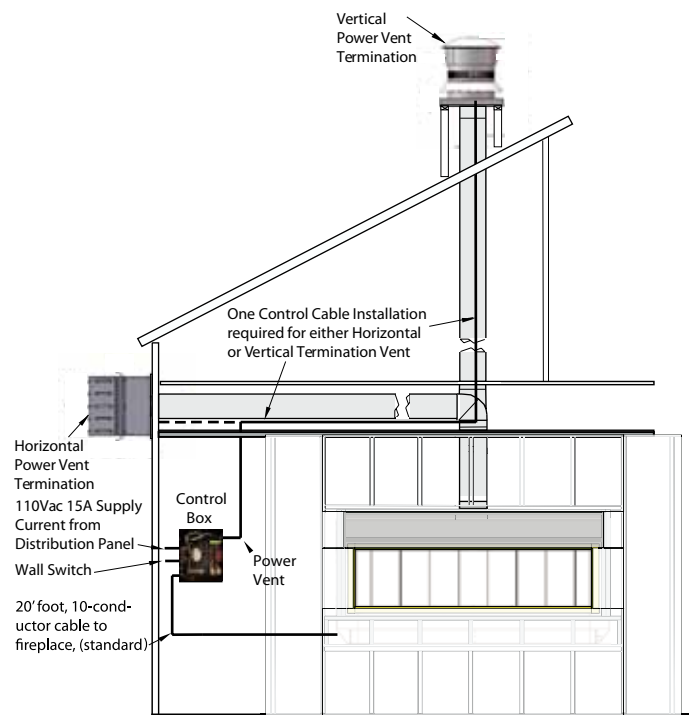

Figure 2a. Milan Series Control Box/Power Vent Wire Routing Diagram

Installation



The Vertical EPVRR Power Vent

Installation Requirements for Vertical Power Venter

The Milan Series fireplaces use a designated coaxial vent system designed specifically for the fireplace and use of non-certified parts will void the European Home warranty and may impede the operation of the fireplace.

The EPVRR power vent dimensions are show below.

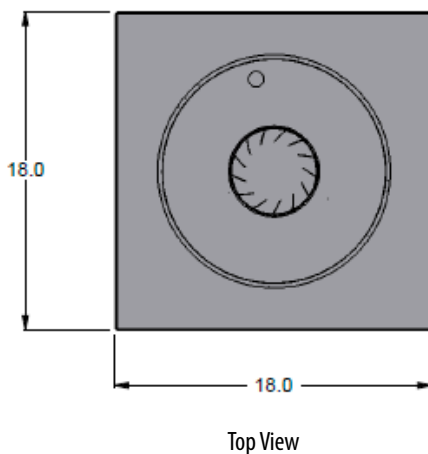
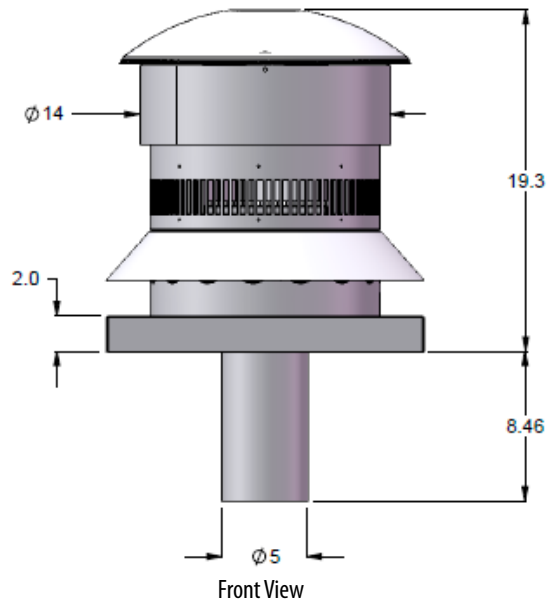

Vertical Power Vent Requirements

It is recommended that the External Power Vent System be used with a gas fireplace that is equipped with HSI. When installing the venting, the installation must adhere to the Vent Installation Section in the fireplace's Installation Operation and Maintenance Instructions, as well as the following guidelines:

- Ensure that the planned termination location is acceptable as shown in Appendix A.
- Maximum allowed vent run is 100 feet. Refer to European Home Technical Support for all variations not described here.
- Vertical runs must be supported by a minimum of three supports per 10 feet of venting.
- For vertical installations the longest vent run is 140 feet with a limit of 6 - 90° elbows, or 12 - 45° Elbows. For longer runs contact European Home.
- It is important that the location of the power vent motor is not exposed to a downfall of water not in excess of the standard rain fall.

The Vertical EPVRRF Power Vent Rough-in Frame

Installation Requirements for Vertical Power Venter Rough-in Frame.

The Milan Series fireplaces use a designated coaxial vent system designed specifically for the fireplace and use of non-certified parts will void the European Home warranty and may impede the operation of the fireplace.

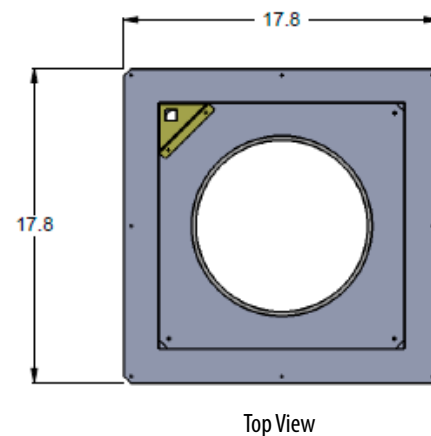
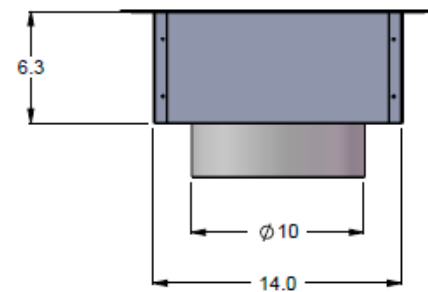



Installation

Available EPVRR Vertical Vent Components

Selecting a Termination Location

Before installing the termination or venting, check to ensure the planned termination location is acceptable and meets basic requirements shown in *Appendix A (Termination Locations)*.

Installing the Terminations with Frame

1. Frame the termination opening for fireplace models, **Milan 60** and **Milan 72**, pages 6 and 7.
2. Fasten the termination and its frame in place using a minimum of 4 screws, installation below.

The following venting components are available for the **Milan 60** and **Milan 72** Top Vent.

	5" / 10" Venting
A - Termination	EPVRR
B - Rough-in Frame	EPVRRF
C - Flex Sections	RFL-1 (12" Section) RFL-2 (24" Section) RFL-3 (36" Section) RFL-4 (48" Section)
D - Rigid Sections	REXT-1 (12" m/f Section) REXT-2 (24" m/f Section) REXT-3 (36" m/f Section) REXT-4 (48" m/f Section)
E - Support Ring & Plate	RSPXT-10
F - Firestop	RS-10

Connecting the Venting

Connect the vent system with a European Home flex section to the fireplace pipe for ease of installation. Flex pipe sections are made in 24" lengths, model **RFL-2**, through to model **RFL-4**, 48" long). When installing these vent components fasten each section with a minimum of three sheet metal screws on the outer flue pipe.

Rigid Vent components are made in 12" sections, model **REXT-1** through to model **REXT-5**, 60" long. Make sure that these inner pipes are connected securely, and slide into each other to a minimum of 1½". Review and compare your vent run to the information in the Exterior Power Vent Installation Section.

Hang the vent components from the ceiling or the wall and maintain 1" clearance around all vent pipe to any combustible materials. When using the European Home flex pipe ensure that the inner pipe is fasten with three sheet metal screws as well as the outer pipe.

Place the springs, supplied with the pipe kit, around the inner pipe before installing the outer pipe over the inner. This will separate the two pipe and avoid any possible hot spots.

Installing the Vertical EPVRR Power Vent

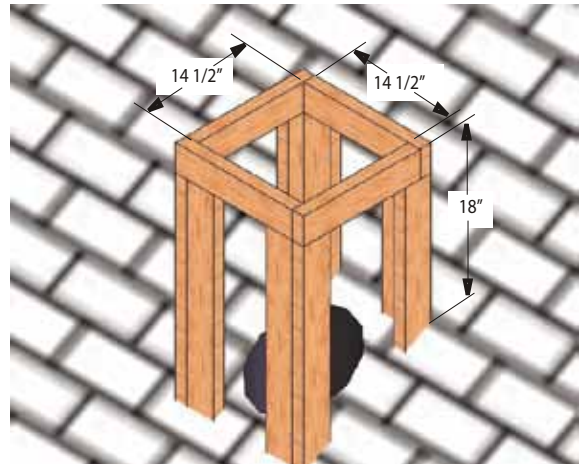

Figure 4.

Step 1.

Construct a chase box around the vent penetration with interior dimensions of 14½" x 14½" x 18" minimum height.

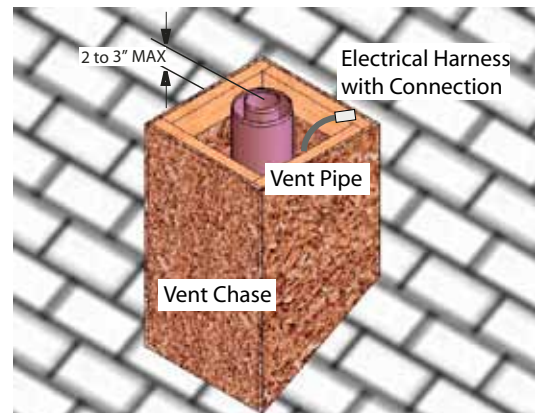

Figure 4a.

Step 2.

Install the vent pipe female end up and 2" to 3" maximum from the top of the constructed chase. At this point install the electrical harness, (EPVH 10-100) that will communicate with the Power Vent Module.

Installation

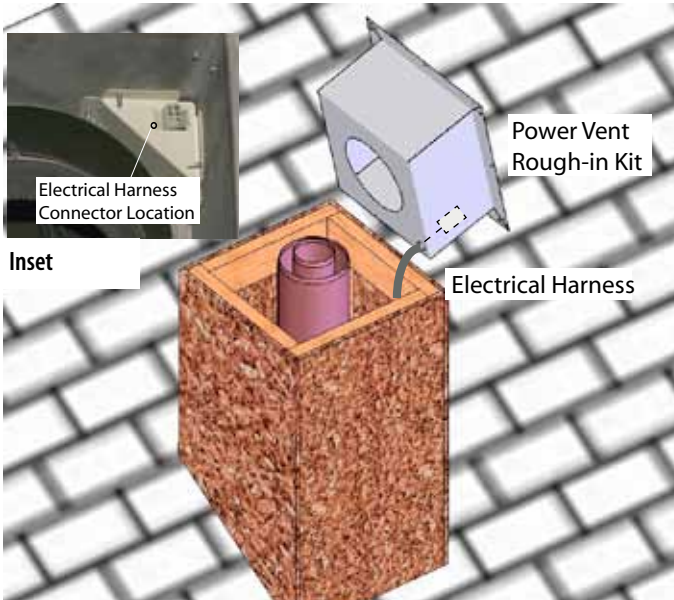

Figure 4b. Installation of Rough-in Kit

Step 3.

Install the Power Vent Rough-in Kit. Pull wire harness through the supplied hole in the bottom corner of the rough-in box, and snap into the slot provided, (See Figure 4b inset).

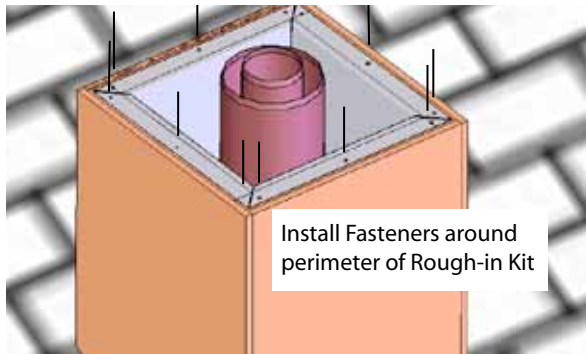

Figure 4c. Fasten Rough-In Kit To Framing

Step 4.

Install Fasteners Around Perimeter Of Rough-In Kit. (Holes supplied for ease of installation)



Figure 4d. (Installed Stainless steel cover)

Step 5.

Install The Power Vent, Roof-Top Stainless Steel Cover Over the Installed Rough-In Kit. (You can see the electrical harness connector in the top right corner).



Figure 4e.



Figure 4f.

Step 6.

Install the Power Vent Module Power/Communication Harness. Hold the power vent in close proximity to the assembled chase, (with stainless steel cover attached) and plug in the power vent communication/power cord. Note the direction and orientation of the plug socket. See Figure 4e & Figure 4f.

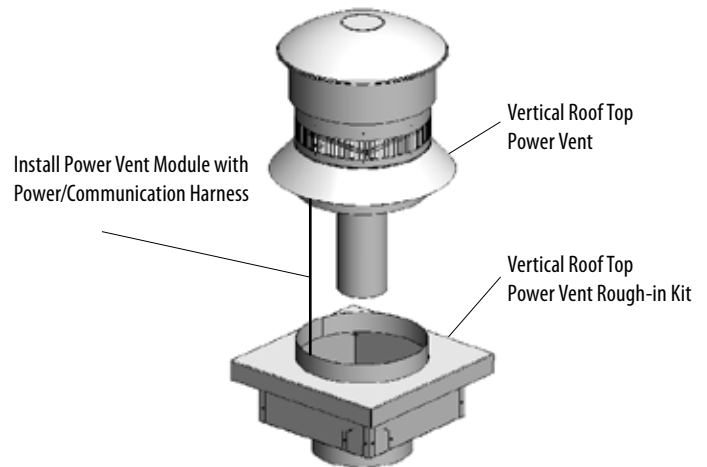

Figure 4g. Installation of Power Vent Module

Step 7.

Install the power vent module. Place the power vent module over the stainless steel cover flange and vent pipe, aligning the power vent into final position. Ensure the harness is placed down in the rough-in box when placing the power vent module into place. The power vent module will sit flush with the stainless steel cover if installed correctly.



Installation

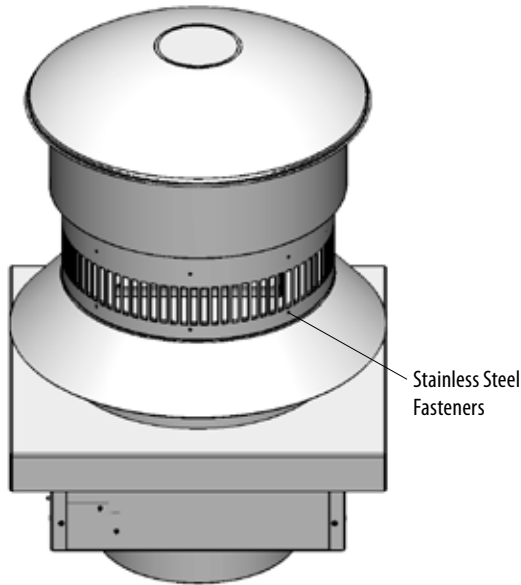

Figure 4h. Installed Power Vent Module

Step 8.

Install (3) three stainless steel fasteners around power vent module at 120 degrees apart penetrating through the inner stainless steel vent cover.

The Horizontal EPVRW Power Vent

Installation Requirements for Exterior Power Venter

The Milan Series fireplace uses a designated coaxial vent system designed specifically for the fireplace and use of non-certified parts will void the European Home warranty and may impede the operation of the fireplace.

The EPVRW Power Vent dimensions are show below.

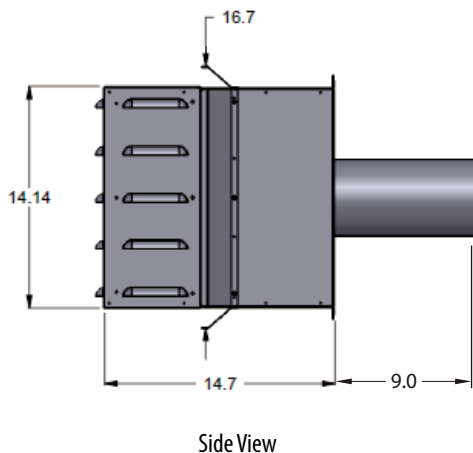

Side View

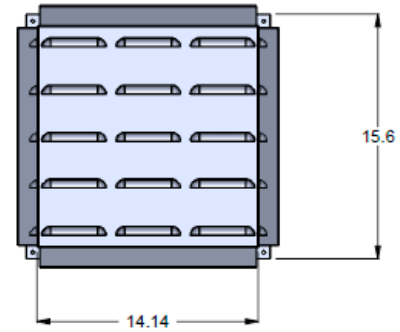

Front View

The Horizontal EPVRWF Power Vent Rough-in Frame

Installation Requirements for Horizontal Power Venter Rough-in Frame.

The Milan Series fireplaces use a designated coaxial vent system designed specifically for the fireplace and use of non-certified parts will void the European Home warranty and may impede the operation of the fireplace.

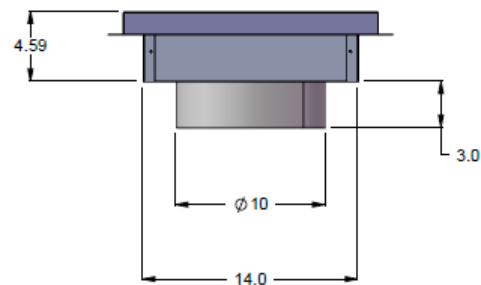

Front View

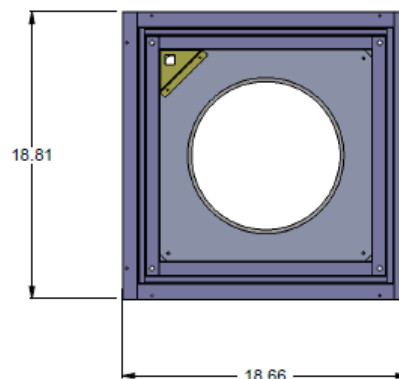

Top View

Installation



Horizontal Power Vent Requirements

It is recommended that the External PowerVent System be used with a gas fireplace that is equipped with HSI. When installing the venting, the installation must adhere to the Vent Installation Section in the fireplace's Installation Operation and Maintenance Instructions, as well as the following guidelines:

- Ensure that the planned termination location is acceptable as shown in Appendix A.
- Maximum allowed vent run is 100 feet. Refer to European Home Technical Support for all variations not described here.
- Horizontal runs must be supported by a minimum of three supports per 10 feet of venting.
- For horizontal installations the longest vent run is 100 feet with a limit of 4 -90° Elbows, or 8 - 45° Elbows. For longer runs contact European Home.
- It is important that the location of the power vent motor is not exposed to a downfall of water not in excess of the standard rain fall.

Available EPVRW Horizontal Vent Components

Selecting A Termination Location

Before installing the termination or venting, check to ensure the planned termination location is acceptable and meets basic requirements shown in *Appendix A (Termination Locations)*.

Installing the Terminations with Frame

1. Frame the termination opening for fireplace models, **Milan 60** and **Milan 72**, on page 10.
2. Fasten the termination and its frame in place using a minimum of 4 screws, installation below.

The following venting components are available for the **Milan 60** and **Milan 72** Top Vent.

5" / 10" Venting	
A - Termination	EPVRW (Wall Vent)
B - Rough-in Kits	EPVRWF (Wall Vent)
C - Flex Sections	RFL-1 (12" Section) RFL-2 (24" Section) RFL-3 (36" Section) RFL-4 (48" Section)
D - Rigid Sections	REXT-1 (12" m/f Section) RXT-20 (20" section) REXT-2 (24" m/f Section) REXT-3 (36" m/f Section) REXT-4 (48" m/f Section)
E - Elbows	REL-90MM (m/m 90° Elbow) REL-90FF (f/f 90° Elbow) REL-90FM (f/m 90° Elbow) REL-45FM (f/m 45° Elbow)

Connecting the Venting

Connect the vent system with a European Home flex section to the fireplace pipe for ease of installation. Flex pipe sections are made in 24" lengths, model **RFL-2**, through to model **RFL-4**, 48" long). When installing these vent components fasten each section with a minimum of three sheet metal screws on the outer flue pipe.

Rigid Vent components are made in 12" sections, model **REXT-1** through to model **REXT-5**, 60" long. Make sure that these inner pipes are connected securely, and slide into each other to a minimum of 1½". Review and compare your vent run to the information in the Exterior Power Vent Installation Section..

Hang the vent components from the ceiling or the wall and maintain 1" clearance around all vent pipe to any combustible materials. When using the European Home flex pipe ensure that the inner pipe is fasten with three sheet metal screws as well as the outer pipe.

Place the springs, supplied with the pipe kit, around the inner pipe before installing the outer pipe over the inner. This will separate the two pipe and avoid any possible hot spots.

Installing the Horizontal EPVRW Power Vent

Selecting A Termination Location

Before installing the termination, ensure that the proper air flow restrictor is installed as shown on page 5, and check to ensure the planned termination location is acceptable. For a detailed illustration of allowed termination locations, see *Appendix A*.

Installing the External PV Termination

Step 1. Construct a frame for the termination opening to 14½" x 14½".

- Maximum allowed vent run is 100 feet. Refer to European Home Technical Support for all variations not described here.
- Allow a minimum of 12" behind the fireplace cabinet for attaching fireplace and power vent collars. Failing to do so could result in misalignment of venting components or the fireplace not fitting as designed.

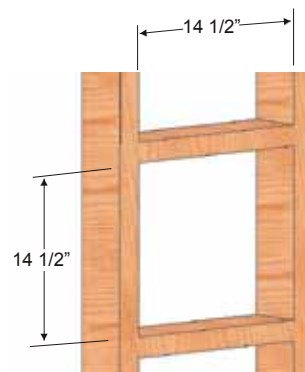

Figure 5. Framing the Opening for Power Vent



Installation

Step 2.

Insert the Power Vent Rough-in Box as shown in *Figure 5*. Fasten the box securely in place with screws or nails, *Figure 5*. Apply exterior sheathing and finishing if required. (*Figure 4a*).

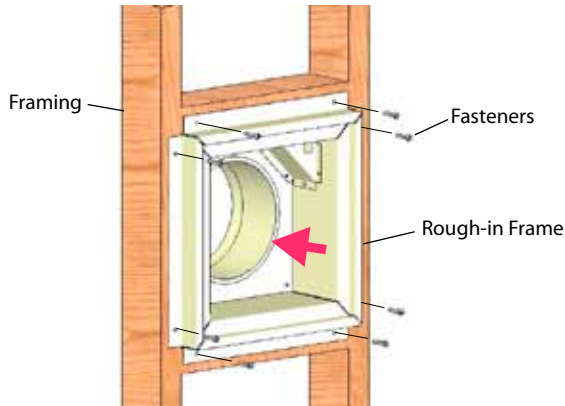

Figure 5a. Orientation, Placing the Power Vent Inner Box

Step 3.

Next, remove the bottom collar and conduit mounting frame as shown *Figure 6*. (Place removed hardware in a handy location for re-assembly).

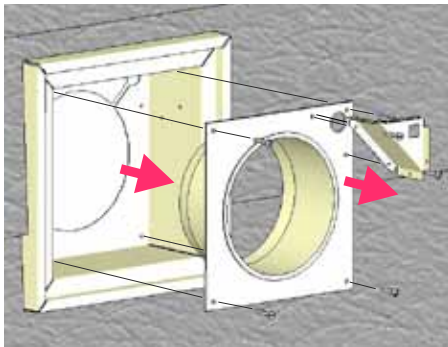

Figure 5b. Installation of Rough-in Kit

Step 4.

Insert the Conduit From the Power Vent Module into the rough-in frame through the *two top right* entry holes. Remove the nut from the supplied strain relief and place as shown, *Figure 5c*.

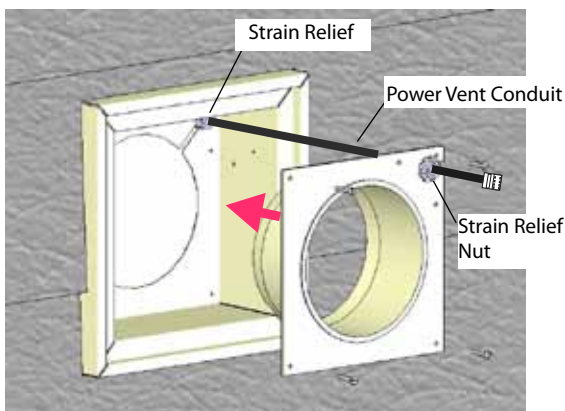

Figure 5c. Installation of Power Vent Conduit

Step 5.

Securely fasten bottom collar pan into the rough-in frame using the existing hardware, (4 pcs.) Tighten strain relief nut onto strain relief.

Step 6.

Pull Power Vent Connector, (*from behind*) half-way through supplied hole in conduit mounting frame, and snap into place, (*notches in two plastic wing clips. Orientation not critical*).

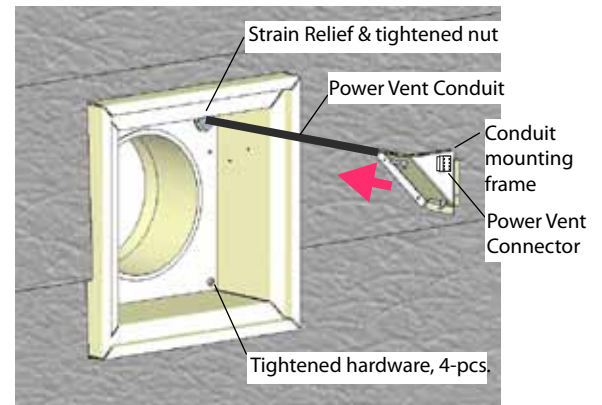

Figure 5d. Installing Conduit Connector And Conduit Mounting Frame

Step 7.

Fasten conduit mounting frame into place using existing hardware, (6 pcs). (*Coil conduit in behind cover.*)

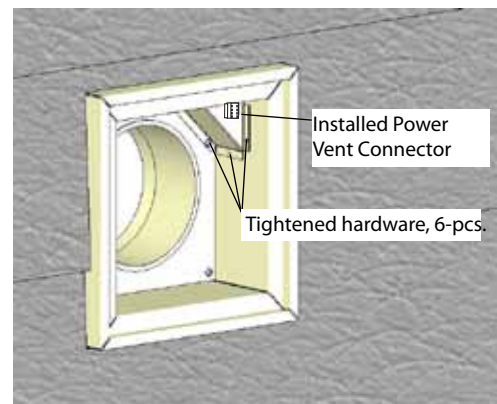

Figure 5e. Assembled Rough-in Kit

Step 8.

Install the Power Vent Power/Communication Harness. Hold the power vent in close proximity of the assembled rough-in kit and plug in the power vent communication/power cord. (*Note the direction and orientation of the pins inside the power vent connector, snap together.*) (*Figure 5f*).

Installation

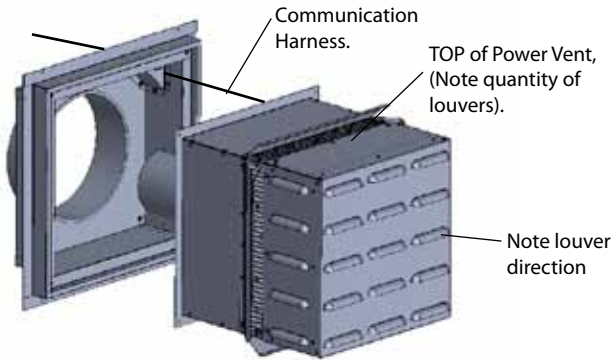

Figure 5f. Installation of Power Vent Communication Harness

Step 9.

Install the Power Vent. Place the Power Vent into the Rough-in frame, aligning the Power Vent into final position. Ensure the Harness is placed down in the Rough-in box when placing the Power Vent. *(Secure the Power Vent in Place with the supplied hardware).*

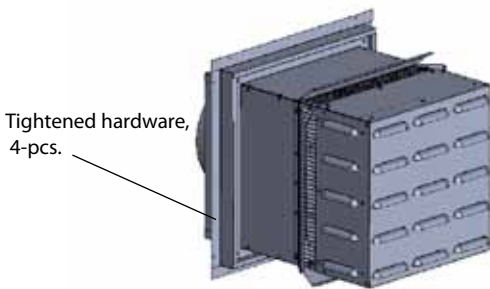

Figure 5g. Completed Installation of Power Vent

Converting to Top Vent / Rear Vent

All Milan Series are boxed and shipped as Top Vent fireplaces. Should your installation specifications require that you install your vent system on the rear of the fireplace, read the following instructions carefully.

1. Remove the eight machine screws that secure the 10" cover plate to the rear vent take off location of the fireplace. *(Ensure you do not damage the fiber gasket)*
2. Then, carefully Remove the 5" cover plate that is installed on the inner rear vent take off location. *(Ensure you do not damage the fiber gasket).*
3. Now, remove the Top vent (5" inner and 10" outer) flue collars. Switch the collars and cover plates as shown in, Figure 10.

CAUTION!

When installing the Rear vent pressure sense tube, aim into the rear vent opening the same way as pictured in this installation, Figure 11. A loose fitting of the flare nut will result in a malfunctioning or problematic fireplace installation.

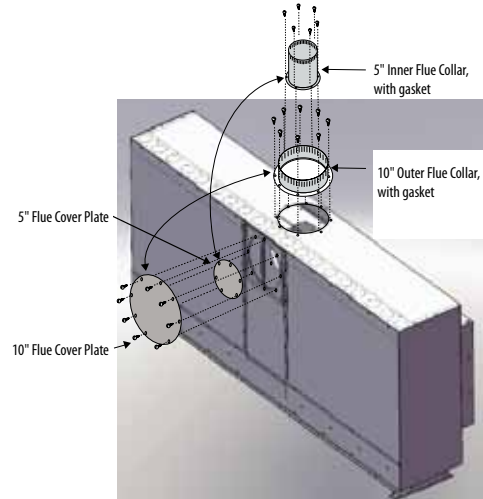

Figure 10. Flue Cap Installation, Top Vented Fireplace.

Converting the Pressure Sensing Tube from Top Vent to Rear Vent

All Milan Series are shipped as Top Vent fireplaces. The fireplace will have installed a formed pressure sensing tube. This tube which is installed at the factory is manufactured of 1/4" aluminum tubing, Figure 11. It will be required to remove the pre-installed 1/4" tube and replace with the supplied Rear Vent Tube as described below.

Aim the pressure sensing tubing (Top Vent or Rear Vent) as shown in Figure 11 to activate the control System. *(Oval below)*

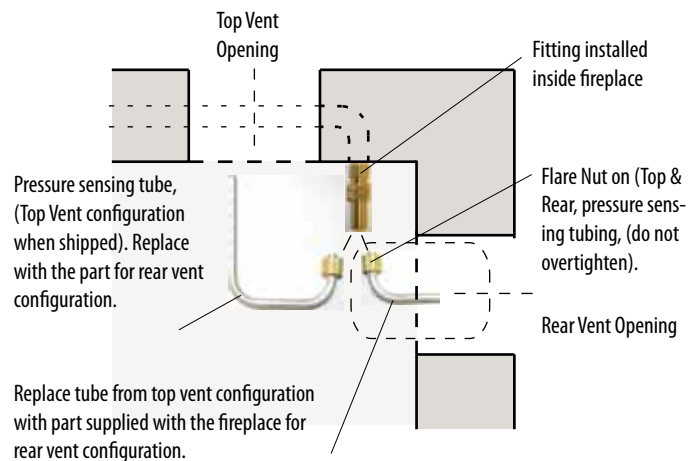

Figure 11. Fireplace Air Proving Switch tubing configuration.

Testing the System

The Milan Series Control and Power Vent System can be safely tested prior to finish framing the Fireplace. This test can be done quickly and efficiently to ensure all systems function according to the design specifications.

The fireplace should be installed on the rough-in frame, Figure 6a with the Power Vent Module and the Vent Termination connected.



Installation

- Note: No gas is needed to prove the system.
- The control panel is supplied with a power cord plug in.
- Plug it into an extension cord or any other 110 volt power supply.



Figure 12. 110V Power Supply

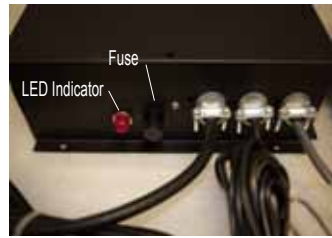

Figure 12a. Fuse and LED Indicator

- If the red LED is illuminated (beside the fuse) you have power to the panel.
- The power vent motor should start running and time out after three to four minutes.
- Turn the wall switch to the on position.
- Observe the two LED on the right side of the panel. If both LED are illuminated and the hot service igniters are glowing red, it is working correctly.

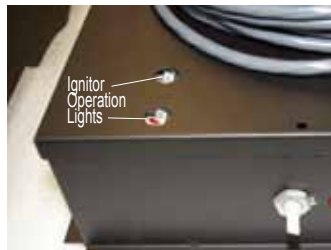

Figure 12b. LED Igniter Indicators

Installing The Gas Line

The gas connection is located on the right side of the lower portion of the fireplace body. The manufacturer requires a service shut off valve located in an accessible location to isolate the gas supply. The gas line must be installed, and tested for leaks before finishing the **Milan Series** fireplace.

Natural Gas requires a minimum inlet gas supply pressure of 5.5" w.c. and a manifold pressure of 3.5" w.c.

Propane requires a minimum inlet gas supply pressure of 11" w.c. and a manifold pressure of 10" w.c. The manifold outlet pressure is set from the factory to the appropriate pressure and should be verified. The manufacturer has provided an inlet pressure tap location in the fireplace for easy access. The control valves have a provision to remove a 1/8" plug so that a hose barb fitting can be installed to check pressure.

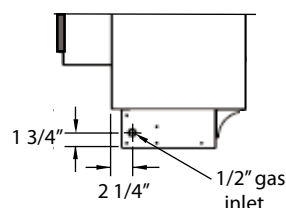

Figure 14. Gas Inlet Supply Location, right-hand side of fireplace.

Note: After the gas line is connected, *each appliance connection, valve and valve train* must be checked while under normal operating pressure with either a liquid solution, or leak detection device, to locate any source of leak. Tighten any areas where bubbling appears or leak is detected until bubbling stops completely or leak is no longer detected. **DO NOT** use a flame of any kind to test for leaks.



WARNING!

When pressure testing the fireplace, gas line, and input system follow the appropriate local codes or your area. **DO NOT** connect the fireplace to pressures in excess of 1/2 psi. This will damage the gas control valve.

Framing for the Milan Series Fireplace

Instructions for framing the platform and enclosure are covered in the following pages. To ensure the fireplace fits as shown in the Specifications please read all the instructions.

Frame the rough-in opening for the fireplace as per the framing instruction with the measurements provided in **Figure 6**. After you frame the enclosure to these measurements install the metal header across the top of the fireplace opening. Install the cement board provided with the fireplace, or replace it with a larger non-combustible board should you find this to your advantage. The bottom of the fireplace may be framed with combustible materials as long as you maintain the clearances required. Install drywall or any other combustible board on the front face of the framing however do not cover the area where the cement board is installed. You may cover this portion with alkyd paint or any non-combustible materials for the area that is designated in **Figure 18**.

Recessing the Fireplace Into the Floor:

You may recess this fireplace into the floor to meet your design requirements. Make sure that the gas connection has been taken into consideration. Maintain the clearances on the back of the fireplace the same way as if you would frame this unit.

Building a Low Profile Enclosure:

Maintain the clearances to the top the sides and the back of the fireplace as per the installation instructions and clearance specifications. Should these clearances not suit your design a cement board enclosure may be an alternative. Keep in mind that the exterior of the enclosure will get hot and decorative items may be damaged.

Note: Minimum clearances will directly translate into elevated temperatures and will still get hot and decorative items placed near the fireplace may be damaged.

Installation



Step 1. To ensure your glass viewing area is at the optimum height, follow the example below, *Figure 16*. Example: If you wish to have the bottom edge of the glass to be 24", the top of the platform will be 13". This dimension takes in account the height of the platform, plywood and adequate clearances.

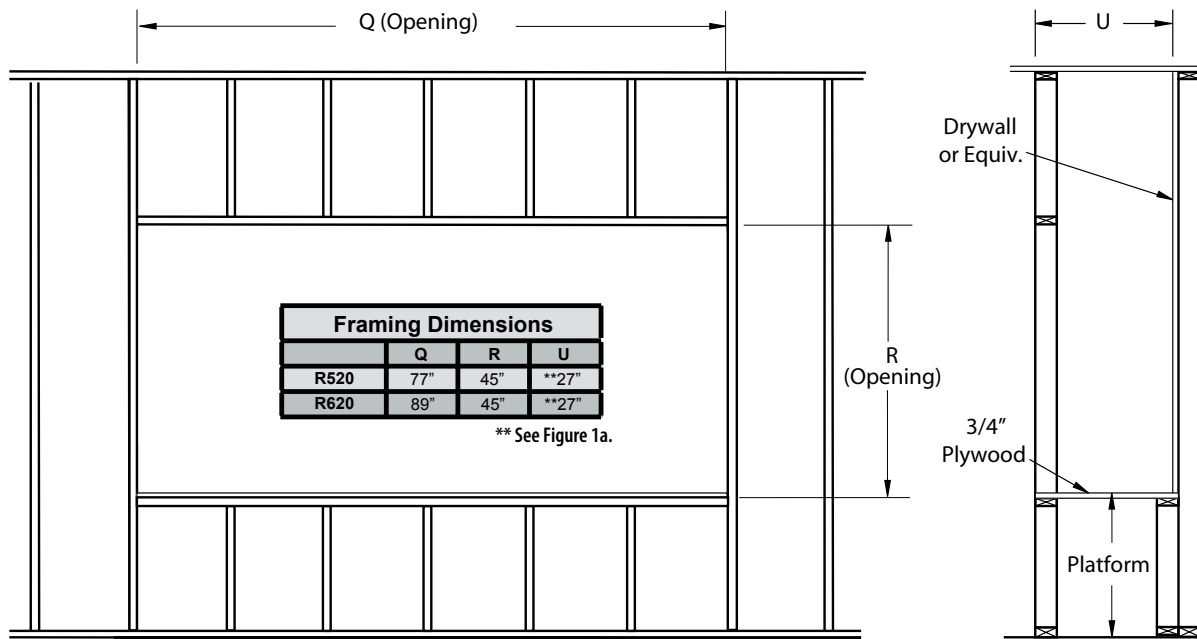

Figure 16. Fireplace installation, *rough-in dimensions*.

Step 2. Place the fireplace on the platform and install the vent pipe, and power vent module. (*Install the module in a location where it can be accessed when the surround is installed around the fireplace*). Next, connect the gas line, and provide a gas service shut-off valve according to local gas codes. Before fastening in place line up the front face of the fireplace (top and bottom), *Figure 6a*, then secure in place with 1/4" wood screws.

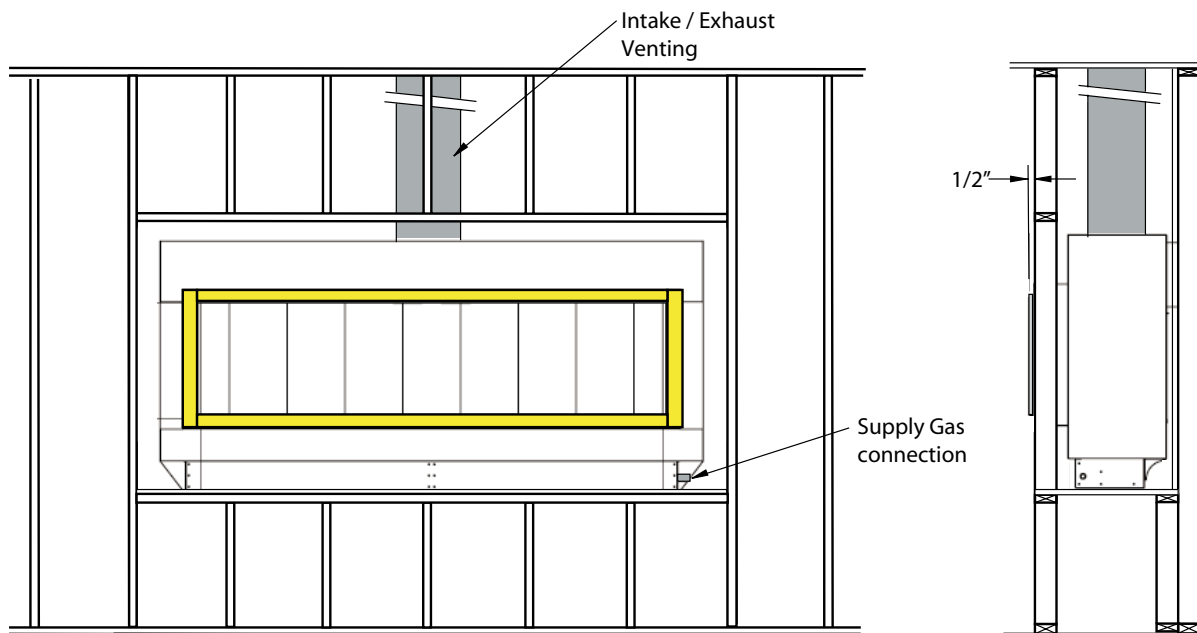

Figure 16a. Fireplace installation, *inlet gas and power vent*.

Step 3. Back-framing the Fireplace; installing 2 x 4's.

Ensure you have the required 2 x 4's to complete the project. Cut one 2 x 4 to fit under the fireplace throat, (horizontal), fit then remove. Next, cut the short 2 x 4's, under the previous horizontal. (*Note: when these pieces are secured into place there should be the required 1" clearance to combustibles.*)



Installation

combustibles), **Figure 16b**. Next, cut four vertical 2 x 4's to install between the upper and lower horizontal 2 x 4's, (2 pcs. either side). (Ensure these are placed the required 1" clearance to combustibles). Cut the top 2 x 4 (horizontal) to fit between the vertical 2 x 4's (either side of fireplace) as shown. Last, install the supplied steel header 1" above the fireplace throat.

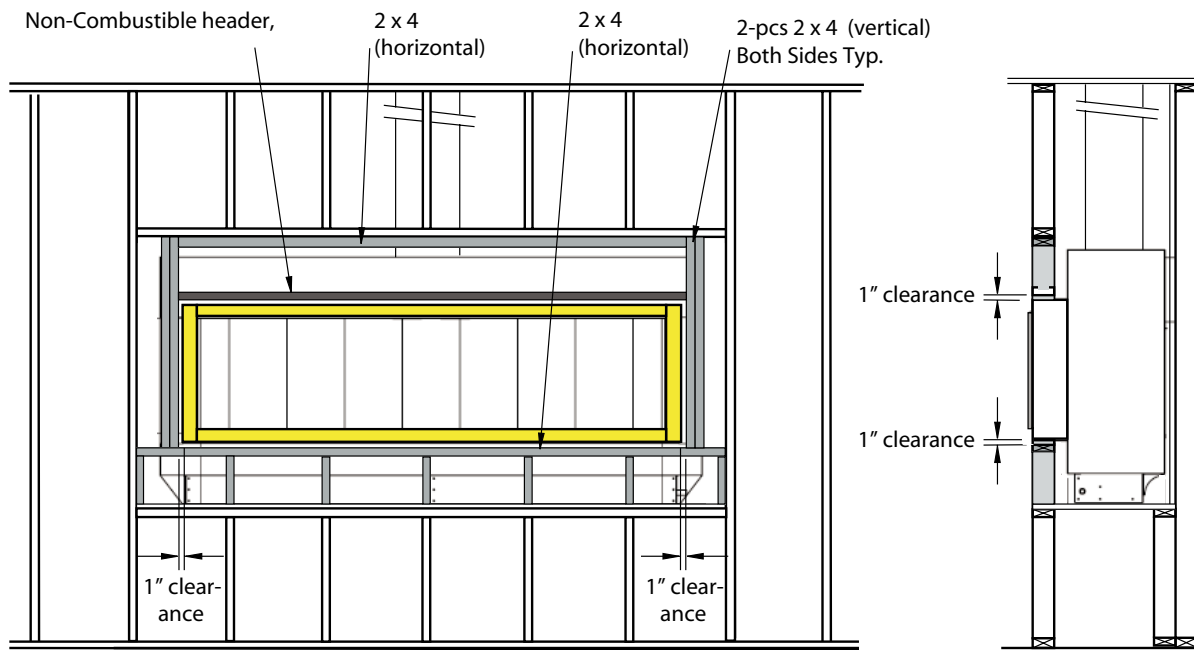

Figure 16b. Fireplace installation, ensure the 1" clearance to combustibles.

Step 4. As shown in **Figure 16c**; cut a sheet of non-combustible concrete board to overlap the new horizontal and vertical 2 x 4's, See **Figure 16b**, above. Place the non-combustible wall board above the fireplace throat, allowing $\frac{1}{8}$ " clearance from the rim above the fireplace opening. Pre-drill the board with $\frac{1}{8}$ " drill and secure to framing with nails, use flat head sheet metal screws to fasten the board to the metal header.

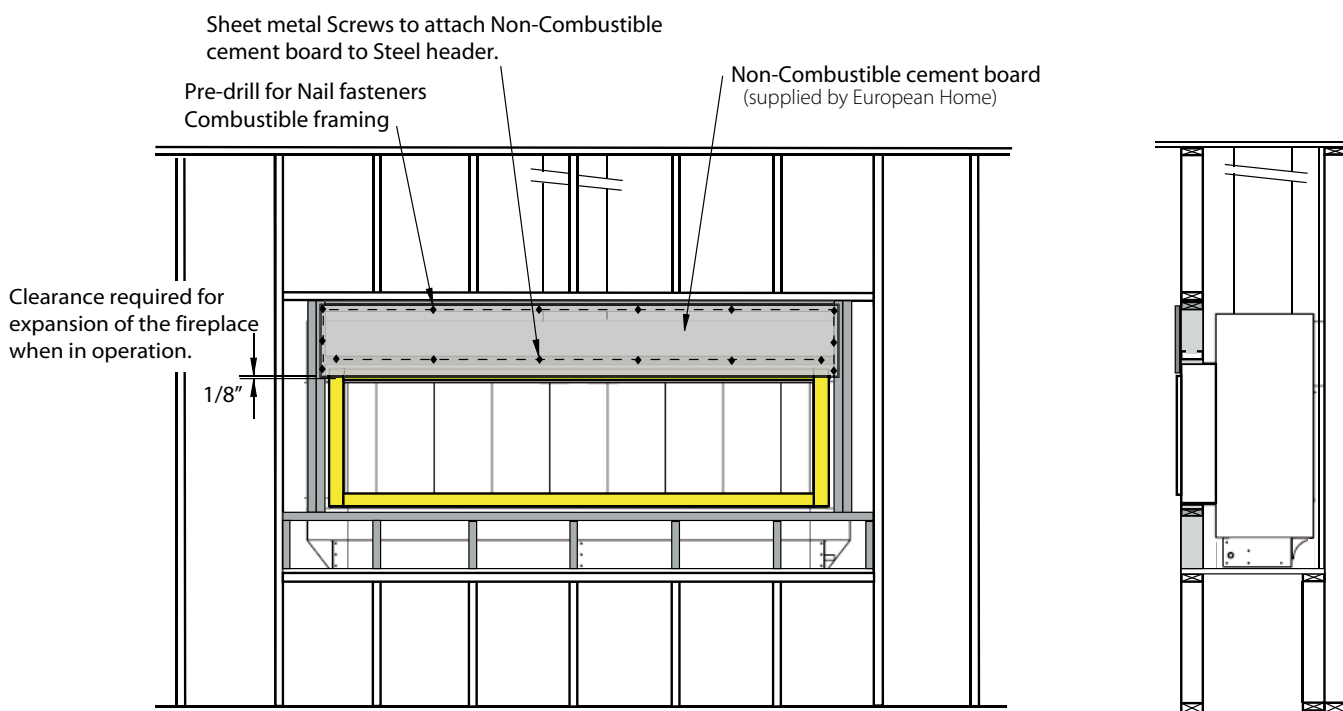

Figure 16c. Non-combustible board over the fireplace.

Installation



Step 5. As shown in *Figure 6d*; Cut standard gyprock/drywall board to complete the installation of the surround. Fit the edge of the board to the rim around the fireplace opening. Fasten the board in place using standard drywall screws.

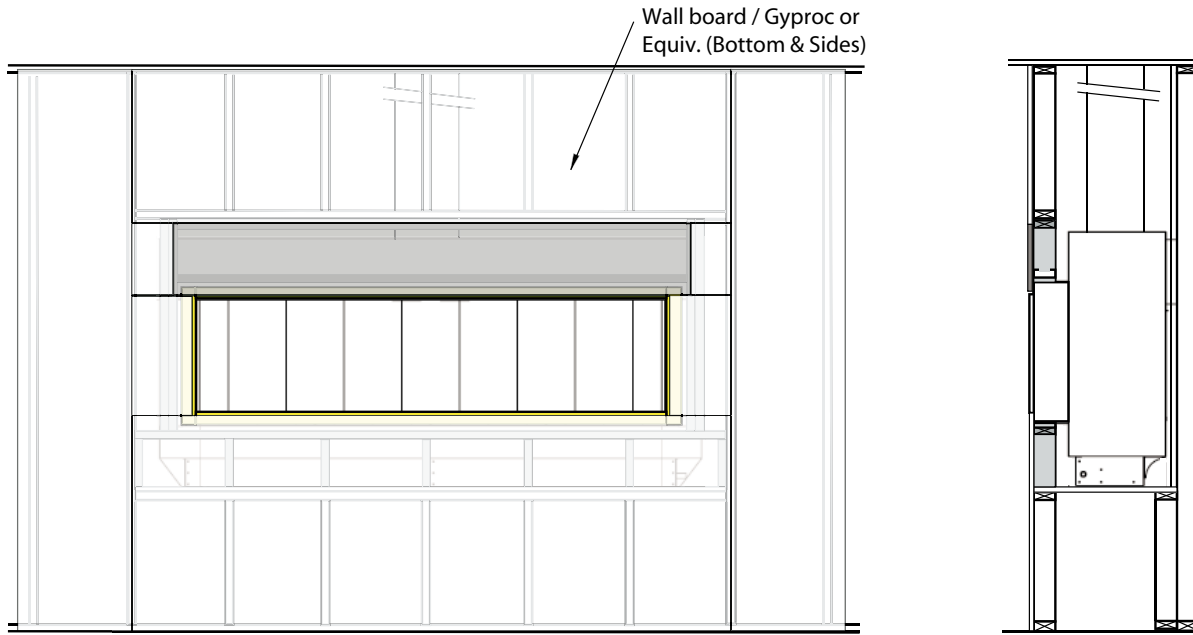

Figure 16d. Fireplace Installation, cut the remainder of gyprock board to complete the fireplace surround.

Finishing Around the Fireplace

Combustible mantels and moldings may be safely installed over the fireplace provided that they do not project beyond shaded area shown in *Figure 18, below*. Side wall clearances are 6".

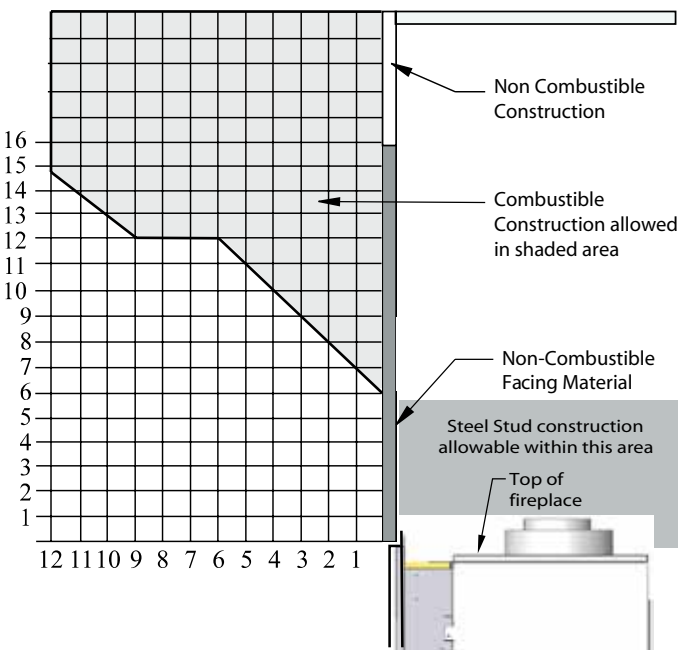

Figure 18. Combustible mantles and facings.

Mantels and Surrounds

NOTE: National Canadian Gas Association mantel test requirements are for fire hazard prevention to combustible materials.

Please be aware that temperatures over the mantel will rise above normal room temperature and walls above fireplace may be hot to touch.

We recommend careful consideration be given to the effects of elevated mantel temperatures which may be in excess of product design, for example: candles, plastic or pictures. This can cause melting, deformation, discoloration or premature failure of T.V. and radio components.

Fireplace Facing

When selecting the finish material for your fireplace, it is important to remember the following: **THE ELECTRICAL CONTROL PANEL MUST NOT BE OBSTRUCTED IN ANY WAY - to do so prevents access for servicing controls.**

The face of the fireplace may be painted to match the room decor, provided you use a heat-resistant paint. Decorative facing must not extend past the fireplace opening at all, because it will interfere with the access to retainers for removal of glass door.

Painting:

Special care is recommended by the Master Painters and Decorators Association, when painting the fireplace surrounds, to select and apply a quality alkyd sealer prior to the applying of latex paints. This is to prevent leaching of water from evaporation and causing a brownish staining effect to paint over coats.



Installation

Electrical Supply Installation

The Milan Series Fireplace is supplied with an external electrical control panel pre-wired by the factory. The power control box is connected to the fireplace with a 20 foot long 6 conductor cable that will communicate with the fireplace. The control panel should be located in a location that would be accessible when the fireplace is finished.



The power cord from the power vent module pugs into the side of this panel. A 20 foot low voltage wire is attached and connected to this panel as well. Connect a single pole on/off switch (black and white) to these two wires at a location of your choice. See *Installing the Remote Switch*.

Installations in Canada must be electrically grounded in accordance with **CSA C22.1** Canadian Electrical Code Part 1 and/or Local Codes.

Installations in the USA must be electrically grounded in accordance with local codes or, in the absence of local codes, with the National Electrical Code, **ANSI/NFPA 70-1987**.

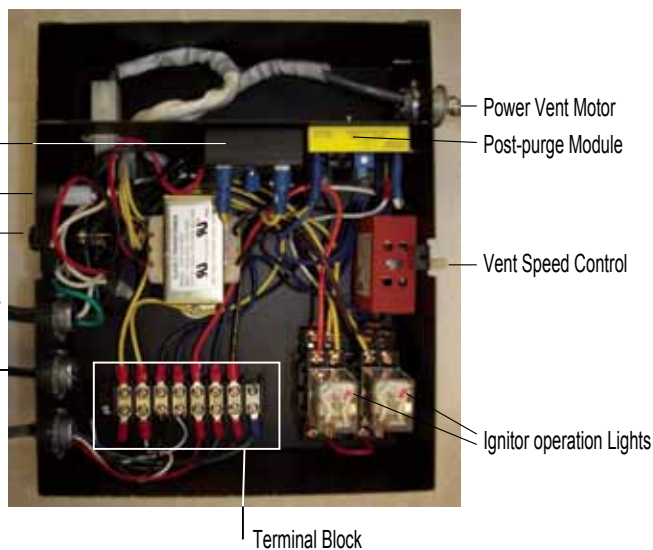

Control Panel
Top View

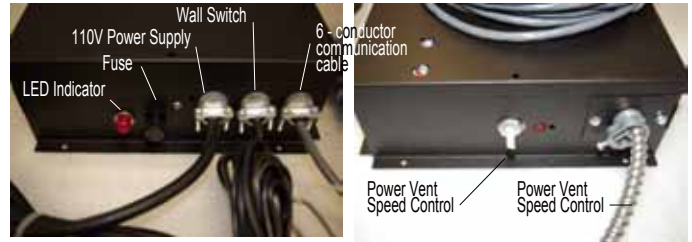

Left-side View

Right-side View

Figure 20. Milan Series Power Vent Module

Installing the Remote Switch

The Milan Series fireplace may be connected to a wall switch or a hand-held remote. The valve operates on a **24V circuit**. **DO NOT** connect the gas valve to an external circuit.



Figure 20a. Remote Switch Wire Connection

The external electrical panel supplied with the fireplace is equipped with a 20 foot low voltage wire, for connecting to a wall switch of your choice. Should you require a longer switch wire, replace this wire to any length with a wire of equal quality. Additional lengths are available upon request.



CAUTION!

The valve has a 30 second time-on delay to clear all build-up of burned gas within the system.

After this delay the fireplace will proceed with the start-up sequence.

Installation



WARNING! If you do not follow these instructions exactly, a fire or explosion may result causing property damage, personal injury or loss of life.

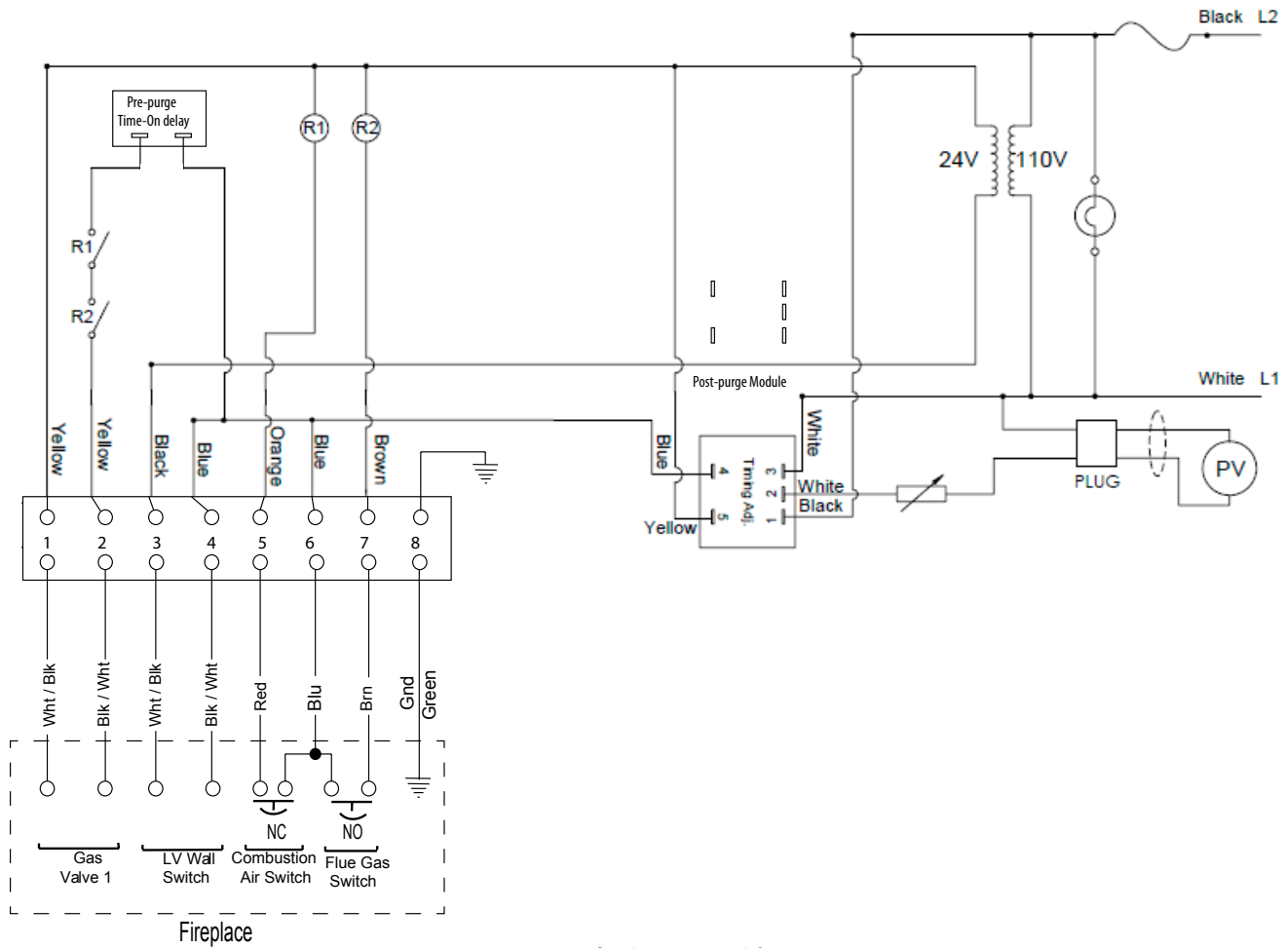

Figure 21. Milan Series Wiring Schematic



Operation

WARNING! If you do not follow these instructions exactly, a fire or explosion may result causing property damage, personal injury or loss of life.

Startup Sequence:

- | | |
|---|--|
| <p>A. Purge all air out of the gas supply line to the fireplace system and ensure that the supply pressure is not in excess of ½" w.c.</p> <p>B. Plug the electrical control panel into the power outlet. The power vent will start and run for about three minutes and then turn off.</p> <p>Caution: Do not turn OFF the power to this panel at this time to operate the fireplace.</p> <p>1. Turn the speed control on the right side of the panel to a low position (clockwise).</p> | <p>2. Turn the wall switch to the "ON" position. The LED on the left of the panel should illuminate.</p> <p>3. Turn the speed up on the speed control knob very slowly until the right LED is illuminated. Note: There will be a 30 second Time-On delay then the burner will fire up. This initial setting will produce the most attractive looking fire. However, you may increase the speed if desired.</p> <p>4. If the right LED is not illuminated when the power vent module is running it will be a signal that the combustion air supply is inadequate.</p> |
|---|--|

CAUTION!

- This fireplace has been set up at the factory for a pre-determined air volume through the venting system.
- This fireplace will not operate unless the correct air movement is detected by our control system..
- Please consulted with your contact person at European Home should you have any problems with your start up.



Operation: With Honeywell Intermittent Pilot

WARNING! If you do not follow these instructions exactly, a fire or explosion may result causing property damage, personal injury or loss of life.

For Your Safety - READ BEFORE LIGHTING:

- | | |
|--|---|
| <p>A. This appliance is equipped with an ignition system that lights the pilot burner automatically. Do not attempt to light the pilot by hand.</p> <p>B. BEFORE LIGHTING smell all around the appliance area for gas. Be sure to smell next to the floor because some gas is heavier than air and will settle on the floor.</p> <p>What To Do If You Smell Gas:</p> <ul style="list-style-type: none"> ■ Do not try to light any appliance. ■ Do not touch any electrical switch; do not use any phone in your building. | <ul style="list-style-type: none"> ■ Immediately call your gas supplier from a neighbor's phone. Follow the gas supplier's instructions. ■ If you cannot reach your gas supplier, call the Fire Department. <p>C. Do not use this appliance if any part has been under water. Immediately call a qualified service technician to inspect the appliance and to replace any part of the control system, and any gas control which has been under water.</p> |
|--|---|

Maintenance



Removing and Installing the Trim and Door

Removing the Trim



Step 1:
Grasp the trim on either side of the door with the tips of your fingers (*both sides typical*) Pull firmly to release the trim from the internal door magnets.



Step 2:
Then pull the trim from the top of the door with your fingers.



Step 3:
Pulling gently remove the trim from the bottom of the door as shown.



Step 4:
Remove the other side, as shown in Steps 1-4.

Removing the Door



Step 1: Remove glass suction cups from box and place on glass door. (May not be exactly as shown). Follow the instructions supplied with this product to ensure ALL of the safety instructions are observed.

Step 2: Place the suction cups on the glass door, spaced evenly. Ensure they are firmly attached and secured.

Step 3: Lifting the glass panel. Hold the tools firmly and lift the glass panel up and out of the lower track and into the upper track. Tilt the lower edge of the door panel outwards.

Step 4: Ensure the top edge of the glass is fully removed from the upper outer track and tilt/lift away cautiously from the fireplace. Store in a safe location until it is time to replace.

Installing the Door

Reverse the previous steps to re-install the Milan Series fireplace door and trim.

Installing the Glass Beads and Optional Fire Media

The Milan Series fireplace is supplied with glass beads. Optional stone and driftwood fire media are available.

Remove the door and trim as shown in the previously. Follow these instructions to ensure all parts are removed or replaced as required. Once the trim and glass doors are removed place the glass beads **AROUND** the burner. The glass beads may be placed on the mesh pilot flame cover but **neither the glass beads nor the fire media may be placed on the burner itself** (see Figure 22, below.)



Figure 22. Finished glass bead installation.

Maintenance



CAUTION!

- Fireplace gas control must be in the "OFF" position and pilot and main burners extinguished when cleaning appliance with a vacuum.
- Doors can get very hot. Handle only when cool.

General

- Have the fireplace installation inspected yearly, including a visual check of the vent system, the burner and the pilot flame. For your convenience a 1/8" manifold pressure tap is supplied on the gas valve for a test gauge connection.
- For **Natural Gas** this appliance requires a minimum inlet pressure of 5.5" w.c. and a manifold pressure of 3.5" w.c.
- For **Propane** this appliance requires a minimum inlet pressure of 11" w.c. and a manifold pressure of 10" w.c.
- Always keep the fireplace area clear and free of combustible materials, as well as gasoline and other flammable vapours and liquids.
- Do not use this appliance if **any part has been under water**. Immediately call a qualified service technician to inspect the appliance and to replace any part of the control system and any gas control which has been under water.

Cleaning

When the fireplace is first activated, there may be some smoking and a visible film may be left on the glass. This is a normal condition, and is the result of burning of protective coatings on new metal.

- Glass must be cleaned periodically to remove any film, a normal by-product of combustion, which may be visible. Film can easily be removed by removing the door as shown on page 8. Handle the door carefully and clean it with non-abrasive glass cleaners. One of the most effective products is Kel-Kem.
- Silicone seals on inner door during initial firing will "off gas", leaving a visual deposit of a white substance on combustion chamber walls. This can easily be removed using normal household products.
- Use a vacuum cleaner or whisk broom to keep the control compartment, burner, and firebox free from dust and lint.



WARNING!

Do not attempt to clean glass when hot.
Do not clean glass with abrasive materials as any glass etching may cause premature glass failure.



CAUTION!

DO NOT OPERATE THIS FIREPLACE WITHOUT THE GLASS DOOR OR WITH A BROKEN GLASS DOOR.

Troubleshooting

HONEYWELL SV9500 /9600 Troubleshooting Sequence

NOTE: Before Troubleshooting, Familiarize Yourself With The Startup And Checkout Procedure.

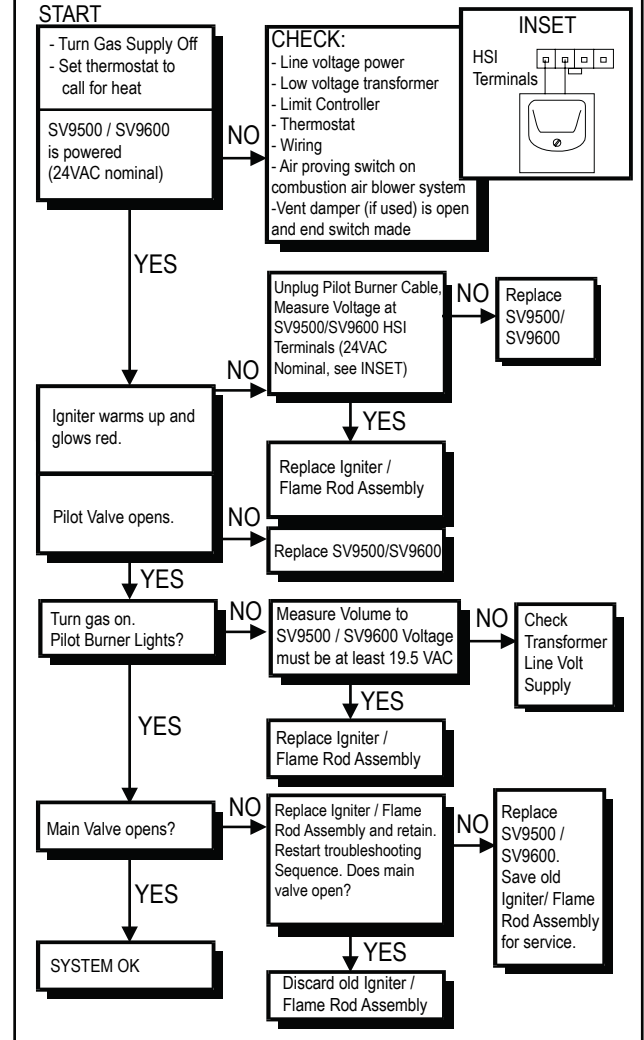



Maintenance

Troubleshooting the Power Vent System

1. Plug the power cord into a 110 volt outlet.
2. The red LED will indicate that you have power.
3. The power vent module will run for three minutes and then it will time out.
4. Turn the wall switch to the "ON" position.
5. The left LED will light up, the power vent module will start running.
6. The right LED will illuminate when the power vent is pulling the correct amount of air through the vent connection of the fireplace.
7. The flue gas proving switch will close the circuit, the right LED will light up.
8. The pre-purge module will close the circuit to the valve after the power vent has run for ½ minute to clear all unburned gases out of the system.
9. The Smart Valve will start the glow plug and light the pilot.
10. The flame sensor will inform the control system in the Smart Valve to fire the main burner.
11. Turn the wall switch off, the burner will shut off immediately and the power vent module will continue to run for three minutes to clear all unburned gases out of the system.

Diagnosing the Power Vent System

SYMPTOMS	Solution
The right delay is not illuminated when the wall switch is "ON"	There is no power check the LED on the left side of the module.
The right relay is not illuminated and the wall switch is "ON" . The power vent is running.	Turn the power vent speed control up to a higher setting. Check the installation of the sensor tube on the inside of the fireplace. Before you re-install the glass front, hold a piece of paper in front of the fireplace opening and ensure the vacuum of the power vent will hold the paper in place.
The left LED is not illuminated, the wall switch is "ON" and power vent is running.	The combustion air switch is sensing a shortage of air in the air supply. Look for any restriction in the air supply vent.

Troubleshooting

If your fireplace still does not operate correctly, consult your dealer or the manufacturer. **All service and repairs should be performed by a qualified agency.** All spare and optional parts are available from your local dealer or the manufacturer.

Gas Control Valve

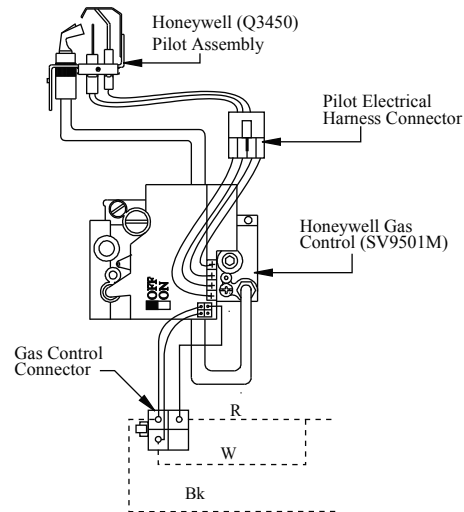

Figure 25. Honeywell SV9501 gas valve.

Warranty

European Home Lifetime Limited Warranty

The Warranty

The Company warrants the European Home Gas Appliance to be free from defects in materials and workmanship at the time of manufacture. On the European Home, there is a ten-year warranty on the firebox and its components, a five-year warranty on the main burner, and a one-year warranty on the pilot burner, gas control valve and fiber logs. Glass, plated/painted finishes, and refractory lining are exempt.

Remedy And Exclusions

The coverage of this Warranty is limited to all components of the Gas Appliance manufactured by The Company.

This Warranty only covers European Home Gas Appliances installed in the United States or Canada.

If the components of the Gas Appliance covered by this Warranty are found to be defective within the time frame stated (see The Company's right of investigation outlined below). The Company will, at its option, replace or repair defective components of the Gas Appliance manufactured by The Company at no charge, and will also pay for reasonable labor costs incurred in replacing or repairing components. If repair or replacement is not commercially practical The Company will, at its option, refund the purchase price of the European Home Gas Appliance.

This Warranty covers only parts and labor as provided above. In no case shall The Company be responsible for materials, components, or construction which are not manufactured or supplied by The Company, or for the labor necessary to install, repair or remove such materials, components or construction. All replacement or repair components will be shipped F.O.B. the nearest Company factory.

Qualifications To The Warranty

The Gas Appliance Warranty outlined above is further subject to the following qualifications:

- (1) The Gas Appliance must be installed in accordance with The Company's installation instructions and local building codes. The Warranty on this European Home Gas Appliance covers only the component parts manufactured by The Company. The use of components manufactured by others with this European Home Gas Appliance could create serious safety hazards, may result in the denial of certification by recognized national safety agencies, and could be in violation of local building codes. This warranty does not cover any damages occurring from the use of any components not manufactured or supplied by The Company
- (2) The European Home Gas Appliance must be subjected to normal use. The Gas Appliances are designed to burn gas only. Burning conventional fireplace fuels such as wood, coal or any other solid fuel will cause damage to the Gas Appliance, will produce excessive temperatures and will result in a fire hazard.

Limitations On Liability

It is expressly agreed and understood that The Company's sole obligation, and purchaser's exclusive remedy under this Warranty, under any other warranty, expressed or implied, or in contract, tort or otherwise, shall be limited to replacement, repair, or refund, as specified above.

In no event shall The Company be responsible for any incidental or consequential damages caused by defects in its products, whether such damage occurs or is discovered before or after replacement or repair, and whether or not such damage is caused by The Company's negligence. Some states do not allow the exclusion or limitation of incidental or consequential damages, so the above limitation or exclusion may not apply to you. The duration of any implied warranty with respect to this European Home Gas Appliance is limited to the duration of the foregoing warranty. Some states do not allow limitation on how long an implied warranty lasts, so the above may not apply to you.

Investigation Of Claims Against Warranty

The Company reserves the right to investigate any and all claims against this Warranty and to decide upon method of settlement.

The Company Is Not Responsible For Work Done Without Written Consent

The Company shall in no event be responsible for any warranty work done without first obtaining The Company's written consent.

Dealers Have No Authority To Alter This Warranty

Company employees and dealers have no authority to make any warranties nor to authorize any remedies in addition to or inconsistent with those stated above.

How To Register A Claim Against Warranty

In order for any claim under this Warranty to be valid, The Company must be notified of the claimed defect in writing or by telephone, as soon as reasonably possible after the defect is discovered. Claims against this Warranty in writing should include the date of installation, and a description of the defect.

Other Rights

This Warranty gives you specific legal rights, and you may also have other rights which vary from state to state.

NOTE: *The Company* as stated above refers to European Home, a division of Europa Ja Inc.

European Home reserves the right to make changes at any time, without notice, in design, materials, specifications, prices and also to discontinue colors, styles and products.

Appendix A - Power Vent Locations

The Vertical EPVRR

Power Vent

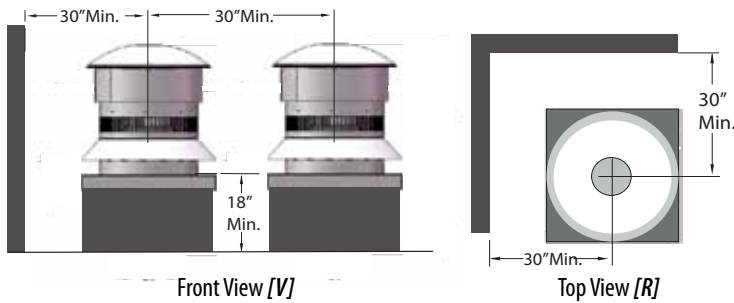

The Horizontal EPVRR

Power Vent

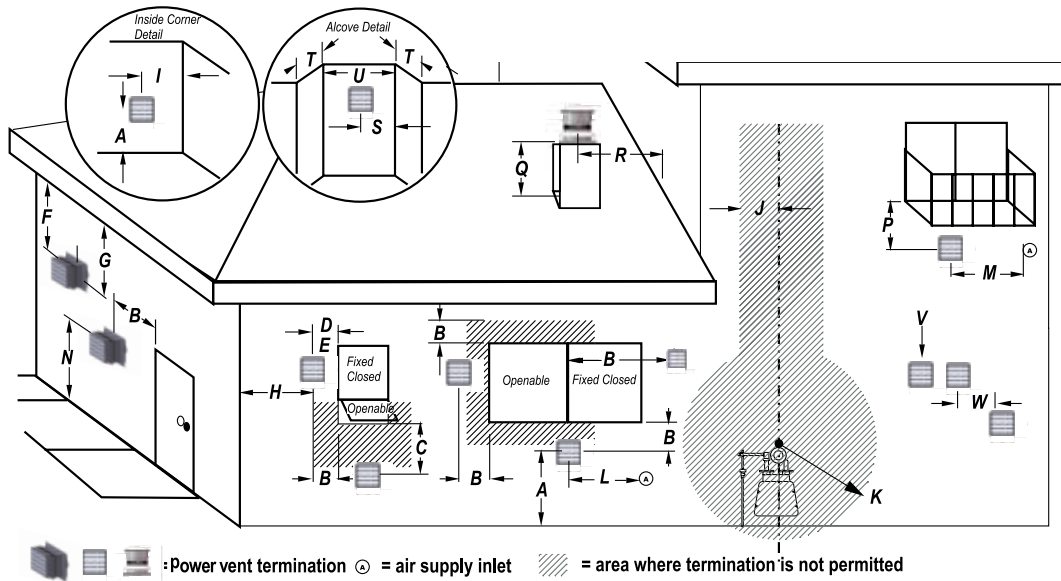
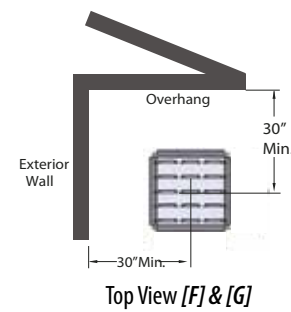

- A** = clearance to the termination frame above grade, veranda, porch, deck, or balcony [30 inches (75 cm) minimum]
- B** = clearance to door, or sides and top of window, that may be opened [30 inches (75 cm) minimum for appliances.
- C** = clearance to bottom of window that may be opened horizontally [36 inches (92 cm) minimum for appliances.
- D** = no clearance to permanently closed window when installed with approved glass penetration termination
- E** = clearance to permanently closed window [30 inches 75 cm recommended to prevent condensation on window]
- F** = vertical clearance to ventilated soffit located above the termination within a horizontal distance of [30 inches 75 cm] from the centerline of the termination [30 inches (75 cm) minimum]
- G** = clearance to unventilated soffit [30 inches (75 cm) minimum to non-combustibles] [30 inches (75 cm) minimum to combustibles]
- H** = clearance to outside corner [30 inches (75 cm) minimum]
- I** = clearance to inside corner [30 inches (75 cm) minimum]
- J** = * not to be installed above a meter/regulator assembly within 40" (103 cm) horizontally from the centerline of the regulator
- K** = clearance to service regulator vent outlet [3 feet minimum in the United States] [*6 feet (1.8 m) minimum in Canada]
- L** = clearance to non-mechanical air supply inlet to building or the combustion air inlet to any other appliance [16 inches (41 cm) minimum for appliances ≤100 000 BTU/H (30kW)]
- M** = clearance to mechanical air supply inlet [*6 feet (1.8 m) minimum]
- N** = † clearance above paved sidewalk or a paved driveway located on public property [*7 feet (2.1 m) minimum]

- P** = clearance under veranda, porch, deck, or balcony [30 inches (75 cm) minimum† to non-combustibles] [30 inches (75 cm) minimum† to combustibles]
 - Q** = clearance above a roof [24 inches (61 cm) minimum]
 - R** = clearance to adjacent walls and neighboring buildings [30 inches (75 cm) minimum]
 - S** = clearance from corner in recessed location [30 inches (75 cm) minimum]
 - T** = maximum depth in recessed location [48 inches (122 cm) minimum]
 - U** = minimum width for back wall of recessed location [60 inches (150 cm) minimum]
 - V** = [30 inches (75 cm) minimum] horizontal clearance between the frames of two terminations that are level.
 - W** = horizontal clearance between the frames of two terminations that are not level. [30 inches (75 cm) minimum]
- † a vent shall not terminate directly above a sidewalk or paved driveway which is located between two single family dwellings and serves both dwellings
- ‡ only permitted if veranda, porch, deck, or balcony has an open side that is equal to or greater than the depth of the enclosed area
- * as specified in CGA B149 Installation Codes. Note: local Codes or Regulations may require different clearance.

Appendix B

State of Massachusetts

Amendment

(Gas Fireplace / Equipment sold in the State of Massachusetts)

5.08: Modifications to NFPA-54, Chapter 10

(1) Revise NFPA-54 section 10.5.4.2 by adding a second exception as follows:

Existing chimneys shall be permitted to have their use continued when a gas conversion burner is installed, and shall be equipped with a manually reset device that will automatically shut off the gas to the burner in the event of a sustained back-draft.

(2) Revise 10.8.3 by adding the following additional requirements:

(a) For all side wall horizontally vented gas fueled equipment installed in every dwelling, building or structure used in whole or in part for residential purposes, including those owned or operated by the Commonwealth and where the side wall exhaust vent termination is less than seven (7) feet above finished grade in the area of the venting, including but not limited to decks and porches, the following requirements shall be satisfied:

1. INSTALLATION OF CARBON MONOXIDE DETECTORS. At the time of installation of the side wall horizontal vented gas fueled equipment, the installing plumber or gas fitter shall observe that a hard wired carbon monoxide detector with an alarm and battery back-up is installed on the floor level where the gas equipment is to be installed. In addition, the installing plumber or gas fitter shall observe that a battery operated or hard wired carbon monoxide detector with an alarm is installed on each additional level of the dwelling, building or structure served by the side wall horizontal vented gas fueled equipment. It shall be the responsibility of the property owner to secure the services of qualified licensed professionals for the installation of hard wired carbon monoxide detectors

a. In the event that the side wall horizontally vented gas fueled equipment is installed in a crawl space or an attic, the hard wired carbon monoxide detector with alarm and battery back-up may be installed on the next adjacent floor level.

b. In the event that the requirements of this subdivision can not be met at the time of completion of installation, the owner shall have a period of thirty (30) days to comply with the above requirements; provided, however, that during said thirty (30) day period, a battery operated carbon monoxide detector with an alarm shall be installed.

2. APPROVED CARBON MONOXIDE DETECTORS. Each carbon monoxide detector as required in accordance with the above provisions shall comply with NFPA 720 and be ANSI/UL 2034 listed and IAS certified.

3. SIGNAGE. A metal or plastic identification plate shall be permanently mounted to the exterior of the building at a minimum height of eight (8) feet above grade directly in line with the exhaust vent terminal for the horizontally vented gas fueled heating appliance or equipment. The sign shall read, in print size no less than one-half (½) inch in size, "GAS VENT DIRECTLY BELOW. KEEP CLEAR OF ALL OBSTRUCTIONS".

4. INSPECTION. The state or local gas inspector of the side wall horizontally vented gas fueled equipment shall not approve the installation unless, upon inspection, the inspector observes carbon monoxide detectors and signage installed in accordance with the provisions of 248 CMR 5.08(2)(a)1 through 4.

(b) EXEMPTIONS: The following equipment is exempt from 248 CMR 5.08(2)(a)1 through 4:

1. The equipment listed in Chapter 10 entitled "Equipment Not Required To Be Vented" in the most current edition of NFPA 54 as adopted by the Board; and
2. Product Approved side wall horizontally vented gas fueled equipment installed in a room or structure separate from the dwelling, building or structure used in whole or in part for residential purposes.

(c) **MANUFACTURER REQUIREMENTS - GAS EQUIPMENT VENTING SYSTEM PROVIDED.** When the manufacturer of Product Approved side wall horizontally vented gas equipment provides a venting system design or venting system components with the equipment, the instructions provided by the manufacturer for installation of the equipment and the venting system shall include:

1. Detailed instructions for the installation of the venting system design or the venting system components; and
2. A complete parts list for the venting system design or venting system.

(d) **MANUFACTURER REQUIREMENTS - GAS EQUIPMENT VENTING SYSTEM NOT PROVIDED.** When the manufacturer of a Product Approved side wall horizontally vented gas fueled equipment does not provide the parts for venting the flue gases, but identifies "special venting systems", the following requirements shall be satisfied by the manufacturer:

1. The referenced "special venting system" instructions shall be included with the appliance or equipment installation instructions; and
2. The "special venting systems" shall be Product Approved by the Board, and the instructions for that system shall include a parts list and detailed installation instructions.

(e) A copy of all installation instructions for all Product Approved side wall horizontally vented gas fueled equipment, all venting instructions, all parts lists for venting instructions, and/or all venting design instructions shall remain with the appliance or equipment at the completion of the installation.

(3) After NFPA-54 section 10.10.4.2 add a new section 10.10.4.3 as follows:

When more than four gas appliances are to be vented through a common gas vent or common horizontal vent manifold, a plan of the proposed vent installation shall be submitted to the Inspector and the serving gas supplier for review and approval.

Extraction from: Massachusetts Rules and Regulations

5.00: Amendments To 2002 Edition Of ANSI Z223.1-NFPA-54



EUROPEAN HOME
a division of Europa Ja, Inc.

376 Washington St.
Suite 203
Malden, MA 02148

tel: 781/324-8383
fax: 781/324-8384
www.europeanhome.com
